

EASI-GLIDE INSTRUCTIONS

Introduction

The Easi-Glide system can be used for Single and Double Door opening configurations.

The maximum door weight is 45kg each.

The system can be used for 35mm and 40mm thick doors. Thicker doors, up to 50mm, will require the Pelmet to be built out from the wall to allow the door to slide past the wall.

Door widths of between 610mm and 915mm can be used.

Single and Double Width Pelmets are supplied over-sized for on-site trimming to suit aperture and door width/s.

Ensure that the wall that the Easi-Glide system is fitted to is not obstructed by skirting boards, light fittings, etc.

Doors cannot be reduced in height from the top door edge lipping: The full lipping thickness is required on the top of the door for secure fixing of the Hanger Bolts. The side and bottom lippings can be trimmed as per the door instructions.

Please ensure that you follow the finishing instructions supplied with the doors.

Storing, installing or finishing the product in a manner not detailed in the instructions may invalidate the warranty.

Prepare the Opening

Ensure that the door/s are of sufficient height and width to cover the Aperture when closed.

Calculate width of pelmet requirement and trim to suit the installation: The pelmet should extend at least 100mm beyond the aperture on the "door closed" side. The pelmet should extend beyond the aperture on the "door open" side by the width of the door plus 100mm.

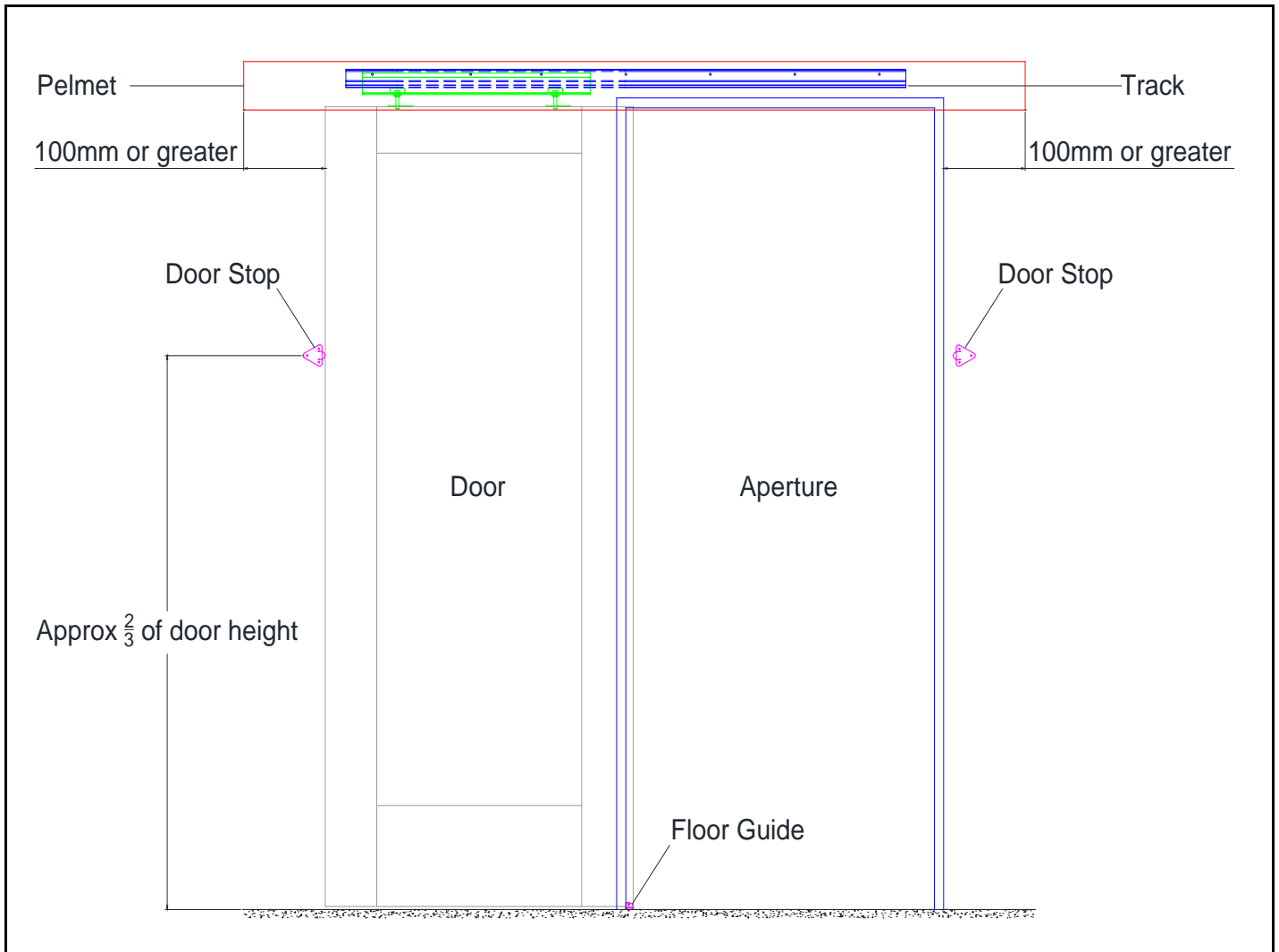

Fit the Hangers to Top Edge of the Door

Mark the Hangers location centrally, 430mm apart from the centre of the door's top edge.

Pre-drill the Hanger bolts.

Drill 10mm holes into the top door edge 38mm deep and place the Hanger bolts into the holes.

Mark the position of the screw fixing holes and pre-drill, prior to permanently fixing the Hanger Bolts screws.

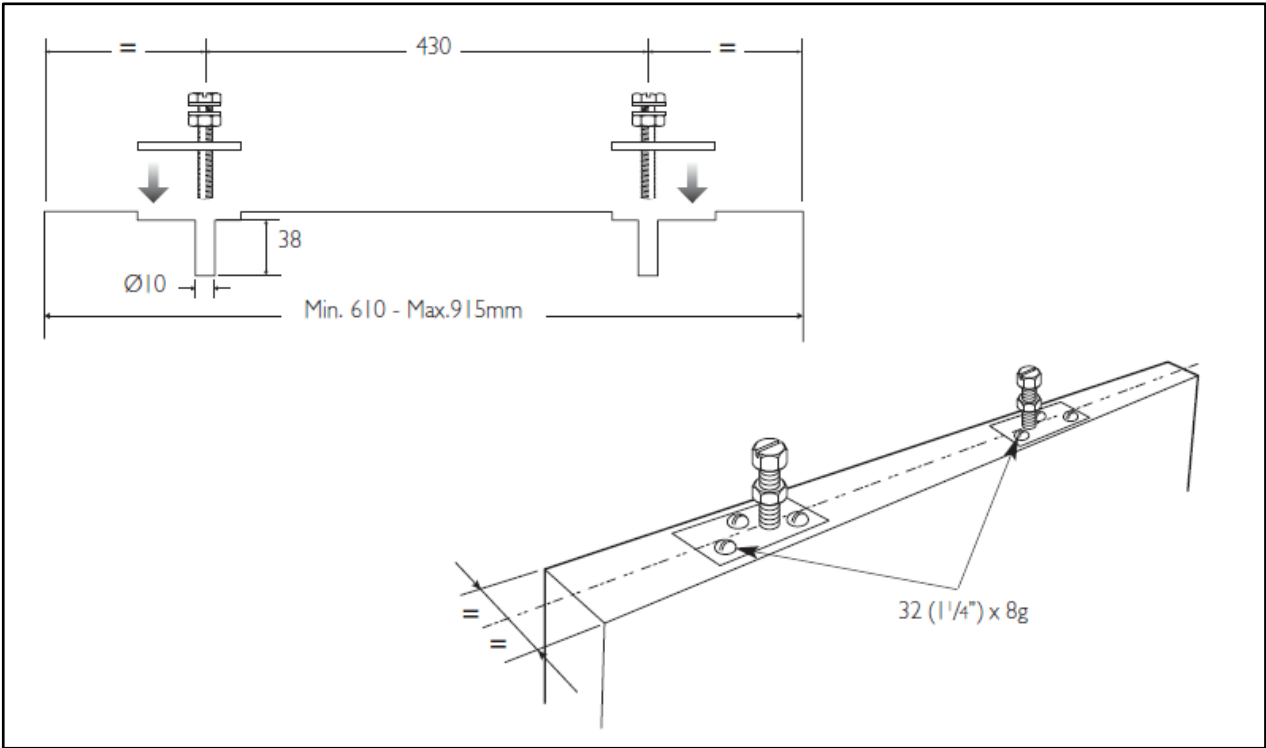

Fit the Track to the Pelmet

Fit the Track through its top horizontal edge into the underside of the Pelmet using 15mm screws.

For double sliding doors, butt two tracks together.

The tracks can be trimmed to allow for narrow door installations: Allow sufficient track length for door(s) to open fully.

The Pelmet Fascia is delivered separately to allow Track and Pelmet fitting.

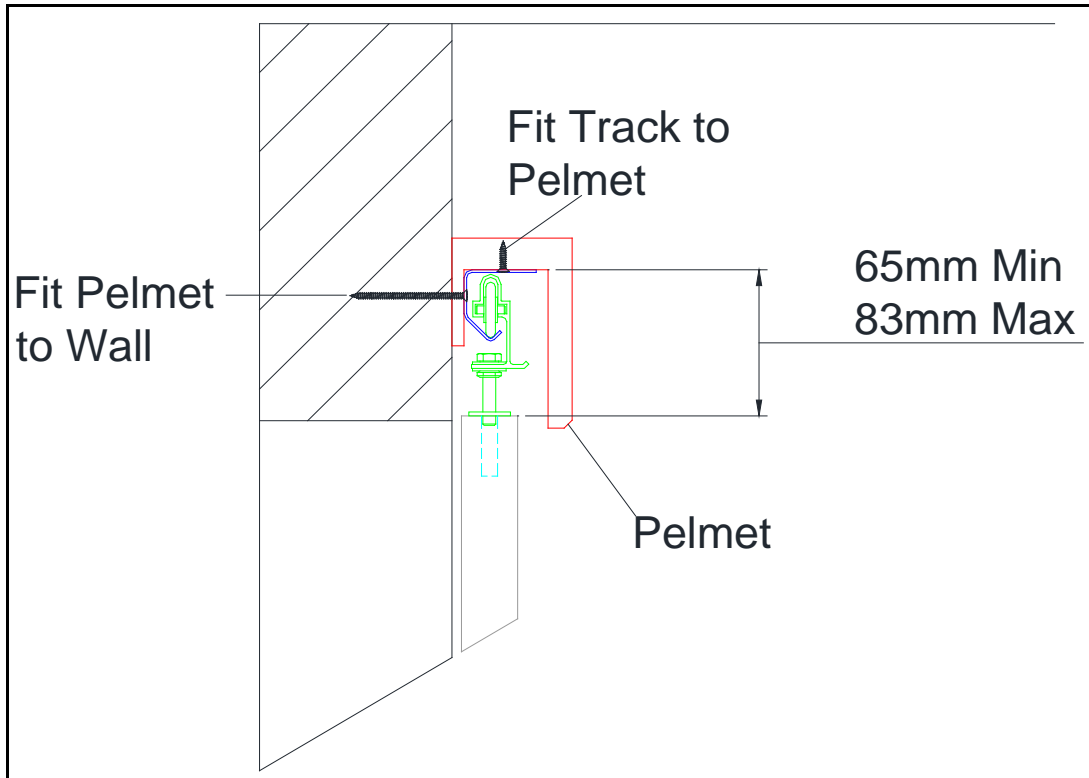

Fit the Pelmet to the Wall

Determine the track height required ensuring there is approximately 5mm between the floor and the bottom edge of the door and that the door covers the height of the aperture.

Ensure that the Pelmet is level and pre-drill through the track holes and Pelmet into the wall.

Secure the Track and Pelmet to the wall using suitable fixings.

Hang the Door onto the Track

Place the Hanger onto the Track.

Slot the Hanger bolts onto the Hanger.

Adjust the Top Bolt until the bottom of the door is approximately 5mm from the floor.

Ensure that the door hangs level and can slide along the track smoothly – ensure that the door does not slide off the track.

Tighten the lower bolt to secure the door to the hanger.

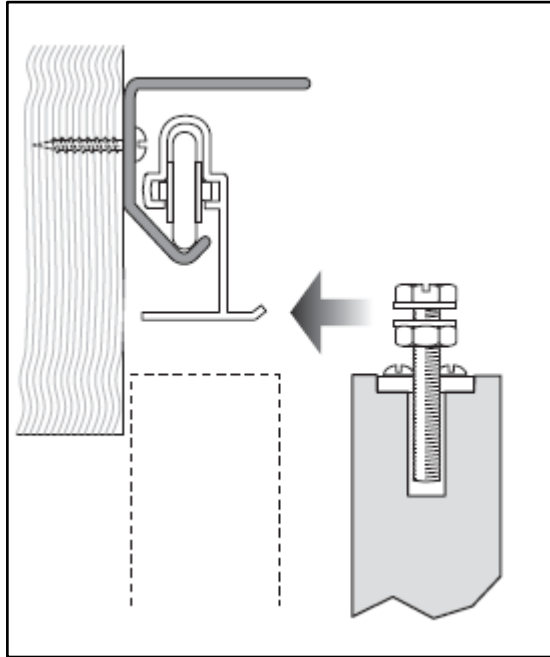

Fit the Floor Guide to the Floor

Assemble the Floor Guide

Fix the Floor Guide to the Aperture reveal where it intersects with the floor

Adjust the Floor Guide to the door thickness with approximately 2mm clearance and tighten

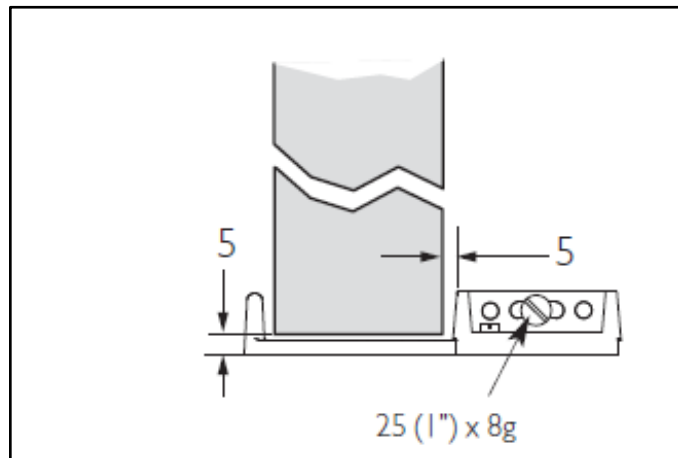

Fit the Door Stops

Fit the 1st Door Stop approximately 1/3 of the door height from the top of the door, with the door located in the open position.

Fit the 2nd Door Stop at the same height, with the door located in the closed position.

Fit the Fascia to the Pelmet

After fitting the Pelmet to the wall and making any hardware adjustments, fit the Fascia to the Pelmet: Ensure that the Fascia is pre-drilled prior to screwing through the pre-drilled Pelmet.

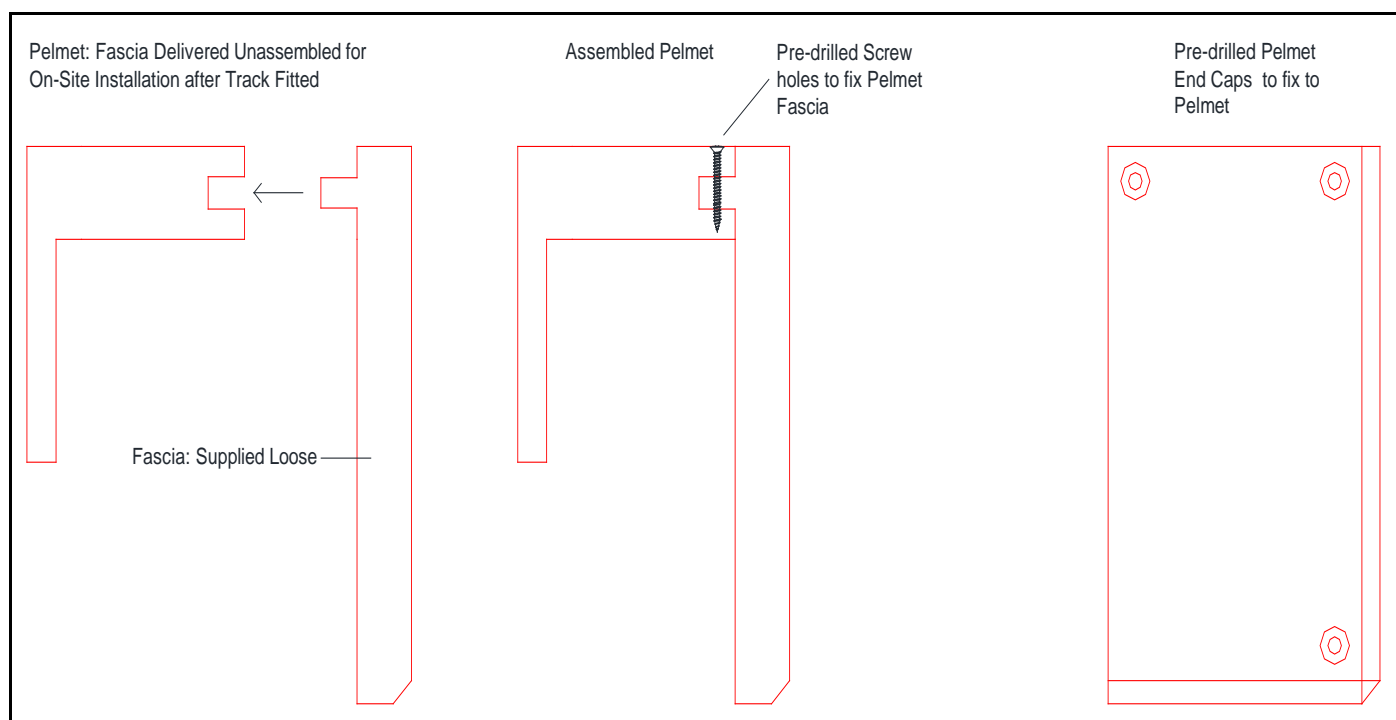

Fit the End Caps to the Pelmet and Fascia

Once the Fascia has been fitted to the Pelmet, the End Caps should be screwed to the Pelmet Ends, pre-drilling through the pre-drilled End Caps first.